

<b>Conference:</b>	XVIII Latinamerican Informatics Conference
<b>Date:</b>	August 31 to September 4, 1992
<b>Location:</b>	Las Palmas de Gran Canaria
<b>Main Topic:</b>	Databases
<b>Keywords:</b>	Object Oriented Database, CASE-Tool, Datamodelling

## **BIER: The Executable Conceptual Data Model Based on an Object Oriented Database System**

Friedrich Kastner  
Paul Andlinger  
Christian Gierlinger  
Werner Retschitzegger

FAW  
Forschungsinstitut für  
Anwendungsorientierte Wissensverarbeitung  
Johannes Kepler Universität Linz  
Altenbergerstraße 69  
A-4040 Linz Austria

### **Abstract:**

During the last years database systems which have previously been limited to commercial and administrative use have made their way into new application domains. On one hand existing data models (especially the relational model) have to be extended and on the other hand new database tools have to be investigated for coping with new

requirements. Recently special attention has been paid to object oriented data models and to the implementation of powerful CASE tools for relational database systems.

In this paper we describe the possibility of combining both concepts and adding dynamic aspects to database systems. This approach results in an executable conceptual data model ("BIER-CASE-Tool"), which represents a dynamic object administration where the routine work (e.g. update processes) is automatically done by the system. In both phases, data modelling and data manipulation, the user works with a special graphic interface.

Our BIER-CASE-Tool works with an underlying object oriented database. The basis of this tool is given by the dynamic data model BIER (Behaviour Integrated Entity Relationship Model) which is able to represent static as well as dynamic aspects of real world objects. The dynamic part which handles the behaviour of objects is described by a petri-net like diagram, called the B-diagram. During the phase of data modelling the user builds this diagram by working with our system.

A further new investigation is that the B-diagram is not only used for drawing and generating the data model, but also for data manipulation. That means, it is not necessary to know any query language because the user is able to do all the database manipulation work by using the graphic interface (the B-diagram).

Figure 1 gives an overview about the components of our system. The kernel of the system is the BIER-library, which holds all functions that are destined to executing the actions the user performs by generating and working with the B-diagram at the database level. In the system tables mainly the information about the B-diagram is stored.

The underlying object oriented database is DAMOKLES. Programming was done in a C environment. The hardware platform used is a SUN SPARC - workstation.

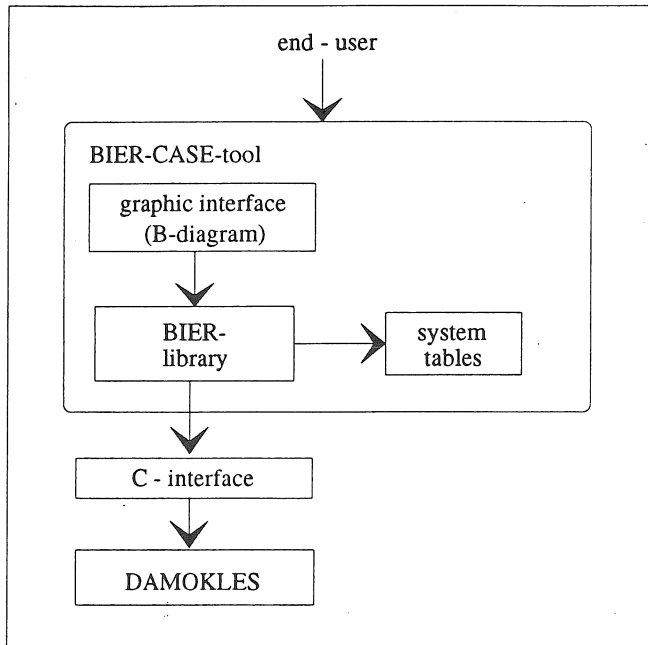

figure 1

The full version of the paper gives an overview about the BIER data model, describes the graphic interface and how the problem of the internal representation of data is solved. The last chapter gives information about results of this project and further activities in this direction.

## References

/EDER 87/ EDER J., KAPPEL G., TJOA A M., WAGNER R.R.: A Behaviour Design Methodology for Information Systems, Proc. IEEE 6th, Int. Conference on Computers and Communications, Phoenix, 1987.

/STONEBRAKER 90/ Stonebraker M., Rowe L.A., Lindsay B., Gray J., Carey M., Brodie M., Bernstein P., Beech D.: Third-Generation Database System Manifesto. SIGMOD RECORD, Vol 19, No. 3, September 1990.

/ABRAMOWICZ 88/ Abramowicz K., Dittrich K.R., Gotthard W., Härtig M., Längle R., Ranft M., Raupp T., Rehm S.: DAMOKLES - Database Management System for Design Applications, Reference Manual, FZI Forschungszentrum Informatik an der Universität Karlsruhe, March 1988.